

# AS/AD

## RADDRIZZAFILO

WIRE STRAIGHTENER - DRAHTGLEICHRICHTER



# cometo

ATTREZZATURE PER FILO METALLICO

AS/AD

AS



AD



# RADDRIZZAFILO AS/AD

WIRE STRAIGHTENER AS/AD  
DRAHTGLEICRICHTER AS/AD

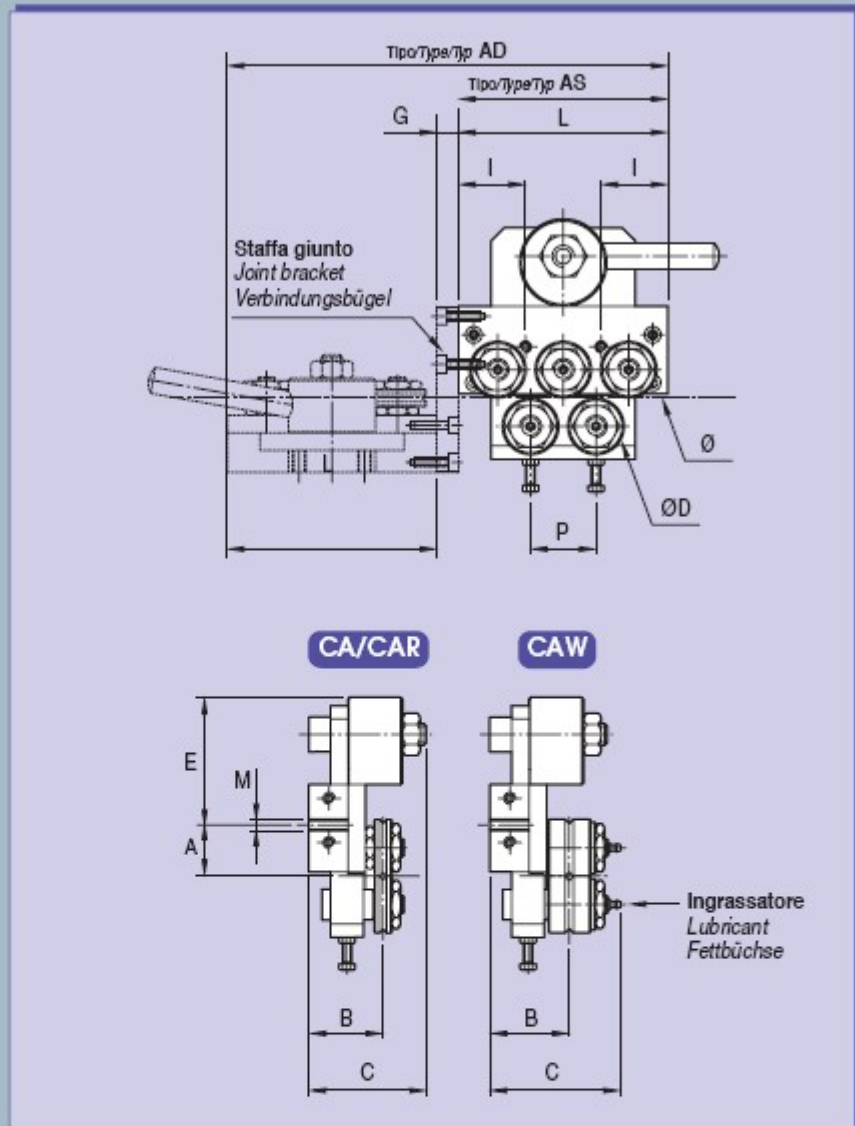

# RULLI

ROLLER  
WALZEN

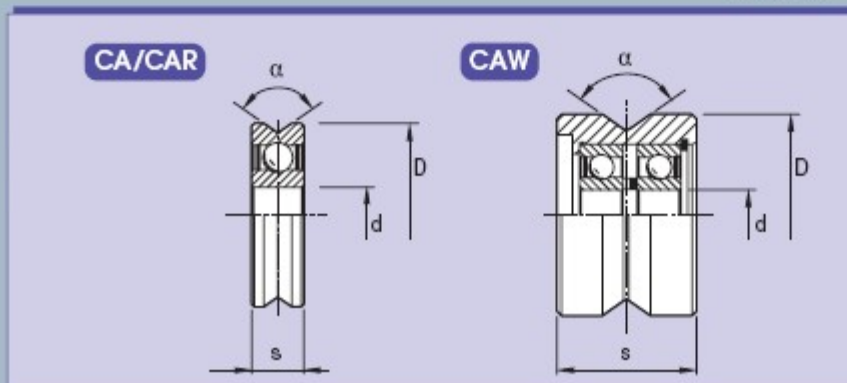



Raddrizzafilo / Wire straightener / Drahtgleichrichter													
Type / Typ	AS13	AS16	AS22		AS30		AS40		AS47		AS62		AS80
Roller Group / Rollen Gruppe	CA13	CA16	CA22	CAW22	CA30	CAW32	CAR40	CAW42	CAR47	CAW47	CAR62	CAW62	CAW80
Ø	0,6	0,6-1	0,6-1,5	0,8-2	1,5-3	1,5-3,7	2,4-4,6	2,5-5-2	3,3-4,5	3,6-7,1	4,4-8,6	5,2-10,1	7,1-14
D	13	16	22	23	30	32	40	42	47	47	62	65	80
d	4	5	8	7	10	10	15	15	15	17	25	25	30
s	5	5	7	21	9	27	11	30	11	33	15	39	47
CL	90°	90°	90°	100°	90°	100°	100°	110°	90°	100°	100°	100°	100°
H	22,5	22,5	33,5	37	43,5	48	62	55,5	62	59,5	62	67	86,5
C	34	35	53	60	73	75	83	66	77	82	100	130	
P	18	20	26	38	55	70	116						
A	18	16,5	24	26,5	27,5	36	37	44,5	43	62			
E	40	44,5	60	65	80	92	114	130					
I	18	25	27,5	36	40	45	70	89					
M	M6	M6	M6	M12	M12	M14	M14	M16					
L Wahlhöhe / Wahlhöhe	5	58	80	88	120	180	200	280	338				
	7	76	100	114	168	235	270	370	443				
	9	94	120	140	196	260	340	460	-				
	11	112	140	166	234	345	-	-	-				
13	130	160	192	272	-	-	-	-					
G	10	70	15	18	20	20	20	28	35				

Raddrizzafilo / Wire straightener / Drahtgleichrichter	Type / Typ	Roller Group / Rollen Gruppe	Diameter / Durchmesser	Resistance / Wire resistance / Drahtwiderstand da N/mm <sup>2</sup>															
				30	40	50	60	70	80	90	100	120	140	160	180	200	220		
AS...13	CA13	25	10'000	0,7	0,65	0,6	0,55	0,55	0,5	0,5	0,5	0,5	0,5	0,5	0,5	0,5	0,4		
AS...16	CA16	25	10'000	0,8	0,75	0,7	0,7	0,65	0,6	0,65	0,6	0,65	0,6	0,65	0,6	0,65	0,55		
AS...22	CA22	20	10'000	1,6	1,5	1,4	1,3	1,2	1,1	1	0,9	0,8	0,8	0,8	0,8	0,8	0,8		
	CAW22			2	2,1	1,8	1,7	1,6	1,5	1,4	1,3	1,2	1,2	1,2	1,2	1,2	1,2	1,2	
AS...30	CA30	20	10'000	3,0	2,7	2,5	2,4	2,3	2,2	2,1	2,0	1,9	1,8	1,7	1,7	1,6	1,6		
	CAW32			3,7	3,4	3,0	2,9	2,8	2,7	2,6	2,5	2,3	2,2	2,1	2,0	2,0	2,0	1,9	
AS...40	CAR40	15	5'000	4,6	4,2	3,9	3,6	3,5	3,3	3,2	3,1	2,9	2,7	2,6	2,5	2,4	2,4		
	CAW42			5,2	4,7	4,4	4,1	3,9	3,8	3,6	3,5	3,3	3,1	3,0	2,9	2,8	2,7	2,7	
AS...47	CAR47	10	5'000	6,5	5,9	5,5	5,1	4,9	4,7	4,5	4,3	4,1	3,9	3,7	3,6	3,4	3,3		
	CAW47			7,1	6,4	5,9	5,6	5,3	5,1	4,9	4,7	4,4	4,2	4,0	3,9	3,7	3,6	3,6	
AS...62	CAR62	5	2'000	8,6	7,8	7,2	6,8	6,5	6,2	6,0	5,7	5,4	5,1	4,9	4,7	4,6	4,4		
	CAW62			10,1	9,2	8,5	8,0	7,6	7,3	7,0	6,8	6,5	6,0	5,8	5,6	5,4	5,2	5,2	
AS...80	CAW80	3	2'000	13,8	12,5	11,6	10,9	10,4	9,9	9,5	9,2	8,7	8,2	7,9	7,6	7,3	7,1		

Per soddisfare le continue esigenze della propria clientela la ditta COMETO ha costruito un raddrizzafilo con due diversi tipi di rulli: Mod. AS per filo R=60 max con rulli normali; e Mod. AS CAW per filo da R=60 a R=220 con rulli in acciaio temperato (62-63HRC).

In order to fulfill the continuous needs of its own customers, COMETO has manufactured a wire straightener with two different types of rollers: Mod. AS for wire R=60 max with normal rollers, and Mod. AS CAW for wire from R=60 to R=220 with hardened-steel rollers (62-63HRC).

Um die andauernden Erfordernisse ihrer eigenen Kunden zu erfüllen, hat die Firma COMETO einen Drahtgleichrichter mit zwei verschiedenen Rollentypen erzeugt: Mod. AS für Draht R=60 Max mit normalen Rollen, und Mod. AS CAW für Draht vom R=60 bis R=220 mit Rollen aus gehärtetem Stahl (62-63HRC).

**SPECIFICHE PER L'ORDINE DEI RADDRIZZAFILI AS...AD**  
 SPECIFICATION FOR AS/AD STRAIGHTENING'S ORDER  
 BESTIMMUNGEN FÜR DEN AUFTRAG DES DRAHTGLEICHRICHTERS

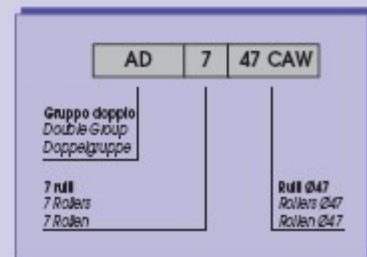
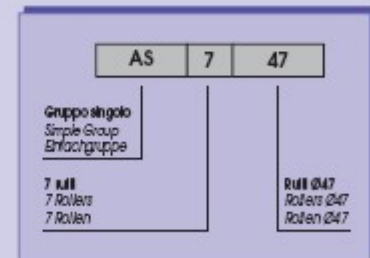
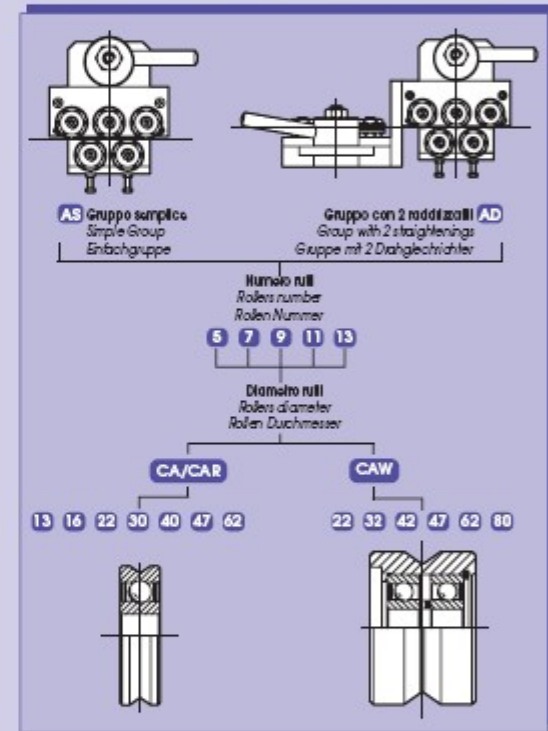



cometo



# AITMAC, INC

**ADVANCED INDUSTRIAL TECHNOLOGIES & MACHINES, INC**

329 Rayette Rd, Unit 14, Concord, Ontario, L4K 2G1. Canada  
E-mail: [sales.aitmac.ca@gmail.com](mailto:sales.aitmac.ca@gmail.com) • <http://www.aitmac-ca.com>  
Tel: (905) 761-6165 • Fax: (905) 761-6168

