

MACCHINA PER TAGLIO E MARCATURA BACCHETTE TIG

MACHINE FOR CUTTING AND MARKING TIG STICKS

MTF 20

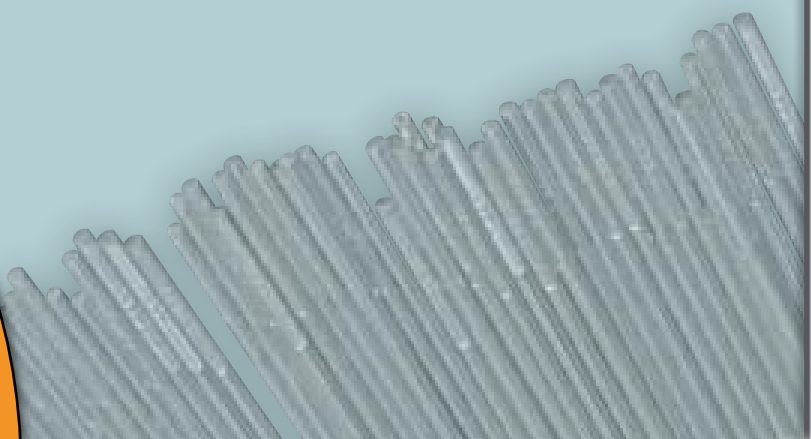

cometo
ATTREZZATURE PER FILO METALLICO

MTF 20

MACCHINA PER TAGLIO E MARCATURA BACCHETTE TIG

Gamma diametri 1.2 - 1.6 - 2.0 - 2.4 - 3.2 - 4.0 - 5.0
in Alluminio - Bronzo - Acciaio inossidabile - Acciaio al carbonio.
Possibilità di marcare entrambe le estremità a lunghezza fissa 1000mm o 914mm.
Completa di accessori per i fili citati.
Lunghezza pezzo controllata da encoder esterno e programmabile da touch-screen.
Produzione massima 100 pezzi/minuto lunghezza 1000mm.
Pressione rulli di traino e rullo encoder regolabile tramite regolatori di pressione pneumatici.
Rulli di traino rivestiti in materiale plastico. Rullo encoder in acciaio temprato 63HRC.
Guide e coltelli in acciaio temprato 63HRC (a richiesta si possono avere le guide in metallo duro).
Regolazione rapida dei raddrizzafili tramite indicatori di posizione.
Bancale modulare che consente di modificare la configurazione della macchina in breve tempo.
Angolare montato a bordo macchina per controllare la lunghezza e la rettilineità del filo tagliato.

MACHINE FOR CUTTING AND MARKING TIG STICKS

It processes aluminium, bronze, stainless steel and carbon steel with diameters 1,2 - 1,6 - 2,0 - 2,4 - 3,2 - 4,0 - 5,0 mm and allows to mark both bar-ends in fixed lengths of 1000mm or 914mm.

Complete with accessories for the different kind of wires.

The wished cutting length in set by means of an external touch-screen, connected to the encoder.

Max. production: 100 pcs/minute for cut length 1000mm.

The pressure of the feed rollers and encoder roller can be adjusted by means of pneumatic pressure devices.

The feed rollers are coated with plastic material. The encoder roller is in hardened steel 63HRC .

Guides and blades are in hardened steel 63HRC (carbide guides available upon customer's request).

Quick wire-straightener adjusting by means of the position indicators.

The modular configuration allows a quick change of the composition of the machine.

The machine is equipped with a fix jig enabling to constantly check the straightening and the length of the cut wire.

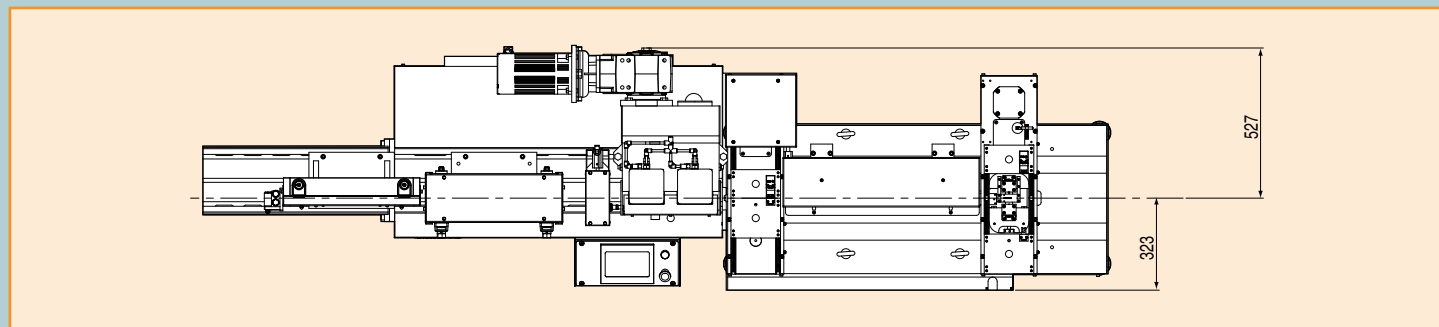
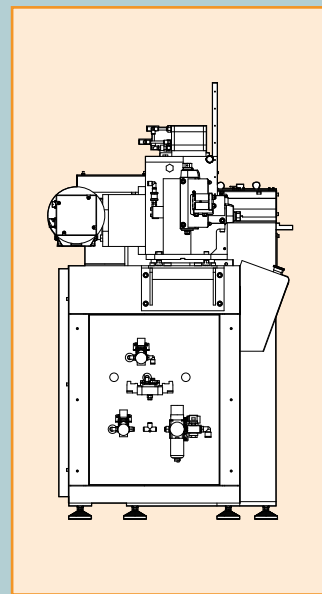
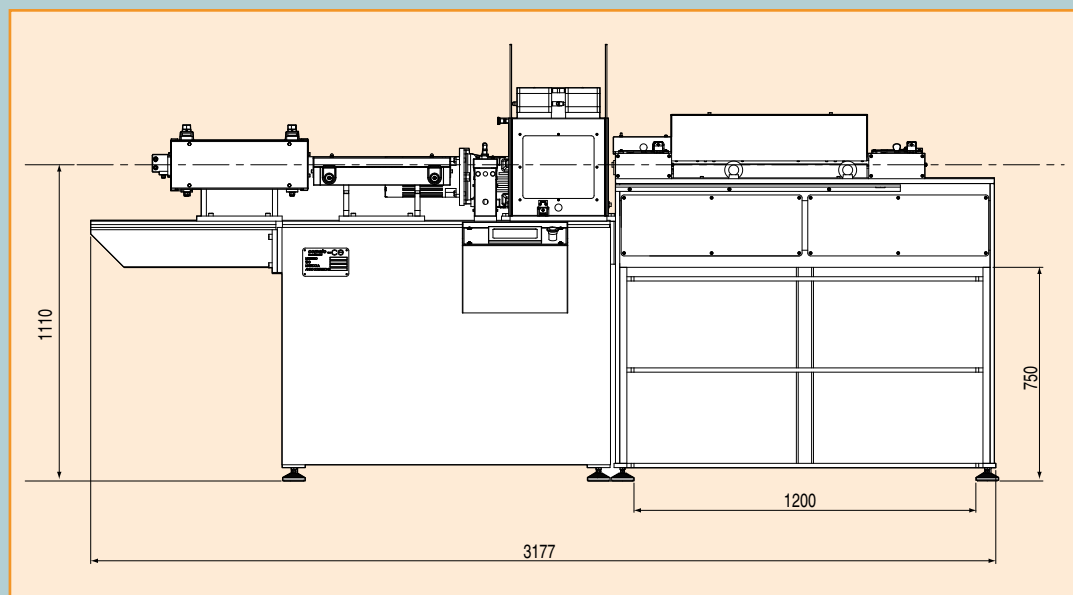

Cometo di Tocchetti Pietro & C. snc

Via Cabella Lattuada, 41 - 23841 Annone di Brianza -LC-

Tph +39-(0)341-263090 - Fax +39-(0)341-260927 - www.cometo.ws - cometo@cometo.eu